



Vacuum packers
swing double
chamber models

VP- 900TBA300

*Industrial vacuum
packer machines
designed for large
productions*



Technical Information

- Entirely made in stainless steel.
- Stainless steel lid.
- Automatic or semiautomatic lid's opening system.
- Double sealing.
- Soft air.
- Gas flushing entrance.
- Vacuum and gas controlled by sensor.
- Digital panel with 99 memory positions.
- Pneumatic sealing bars wireless.
- Inlet plate for height adjustment of the vacuum chamber.
- Easy maintenance.
- 300m³/h Busch pump.

Options

- Independent sealing control & bag cut off.





Measures

A	2,050 mm.
B	1,020 mm.
C	1,050 mm.

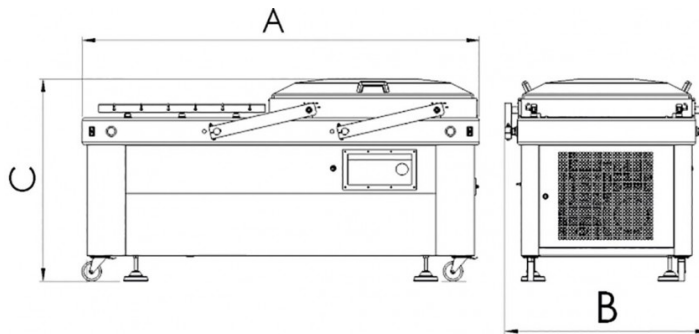

Control panels

Sensor control panel with gas



- Digital control panel.
- Vacuum control by sensor.
- Gas flushing entrance control by sensor.
- Sealing time regulation.
- Soft-Air.
- VAC-STOP push button, finish the vacuum and continue the process.
- VAC+ push button, additional vacuum time.
- Maintenance push button control.
- 99 memory positions.
- Monitoring step by step of the cycle through led.

Combinations of welding rods

VP-900TBA300 AA

